



KUSTOM FIBERGLASS LIDS

visit our website: www.gaylordslids.com

Installation Instructions for Gaylord's Kustom Lid with Type 2 Hinge

WARNING: If you are not familiar with the use of hand tools or are not accustomed to working on motor vehicles, have a dealer or accessory shop install the Kustom Lid. Carefully read all the instructions prior to attempting to fit the Lid. Before fitting the Lid, part the vehicle on level ground in a well lit area and apply the emergency brake. After installation, check that the Lid works correctly and securely locks shut. Periodically check all fasteners for tightness. Retighten only the loose fasteners. When using power or hand tools, always wear the correct protective clothing recommended by the tool manufacturer.

Parts List:

In addition to the Lid, check to make sure that you received everything listed or shown here. If any parts are missing contact your dealers or Gaylord's.

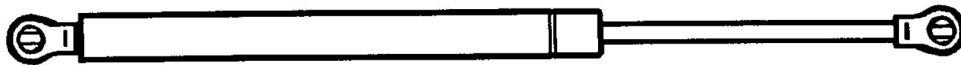

2 - Lid Lifters (Gas Springs)
Note: Exact size depends on your truck.

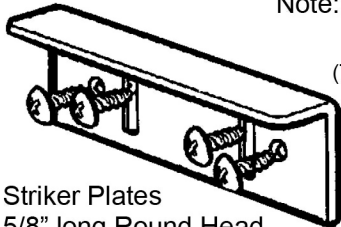

2 - Striker Plates
8 - 5/8" long Round Head Sheet Metal Screws

(Type of Striker depends on Truck)



2 - Stainless Steel Striker plates with adhesive backing

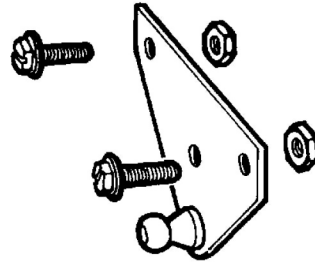

2 - Lower Lid Lifter (Gas Spring) Mounting Brackets
4 - 3/16" x 5/8" Long Bolts
4 - 3/16" Nuts

4 - 5/8" Long Round Head Screws



(Use when nuts & bolts for Lid Lifter Bracket cannot be used)

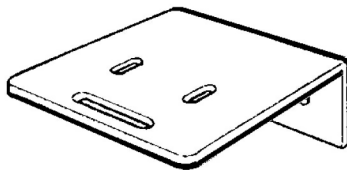

2 - Type 2 Front Hinge Brackets (size will vary according to truck type)

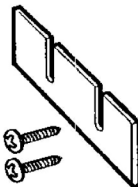

4 - Plastic Spacers
8 - Front Bracket Mounting Screws

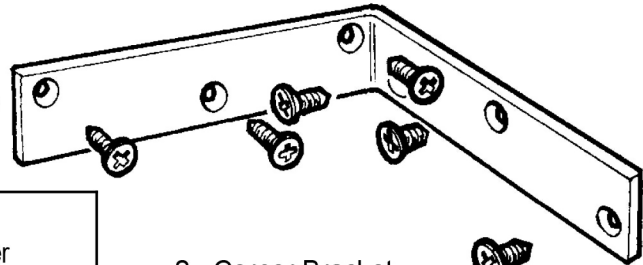

2 - Corner Bracket
12 - 3/4" long Flat Head Sheet Metal Screws

Tools Required:

- Power Drill, AC or Cordless
- 1/16", 1/8", 3/16", & 1/4" high speed drill bits
- 2 - 3/8" Wrenches
- 2 - 17 mm Wrenches
- #2 Phillips Screwdriver
- Flash light
- Tape measure
- Masking tape
- Grease Pencil

FATAL MOTORSPORTS / 3040 N Simmons St #102, North Las Vegas, NV 89032 (702) 363-9779

1 The sides of the Hinge Tabs shown as "A" & "B" should be marked on both sides the Lid. Use a grease pencil.

2 Place the Lid on the truck bed and adjust so it's even on both sides. The rear surface of the Lid should be $\frac{1}{2}$ " or slightly less from the outside surface of the Tailgate. Transfer the marks you made in Step 1 to the outside of the Truck Cab. Be accurate since these marks will be used by you to locate the Front Hinge Brackets.

$\frac{1}{2}$ " or slightly less
between rear surface
of Lid and outside
surface of tailgate.

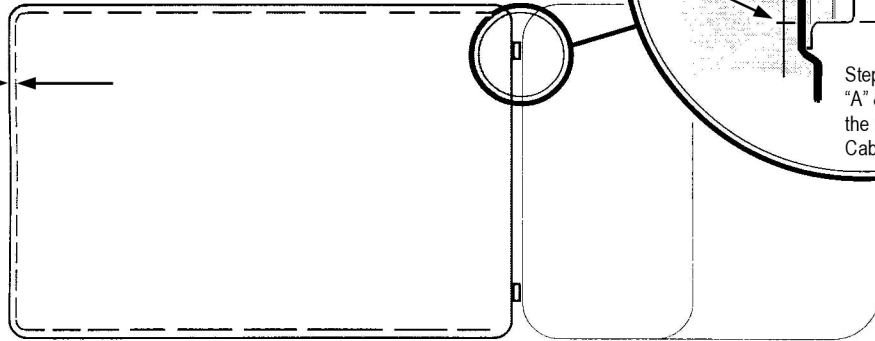

Figure 1 & 2

3A If you have a bed liner in your truck bed, you may have to modify it so the Front Hinge Bracket will fit correctly. If the top of bed liner is higher than the top of the bed rails, then it should be notched as shown on the far right. The mounting surface for the Hinge Bracket should not be more than $\frac{1}{8}$ " higher than the bed rail.

Some bed liners only need the tops of the ribs be trimmed so that the Hinge Bracket will sit flat.

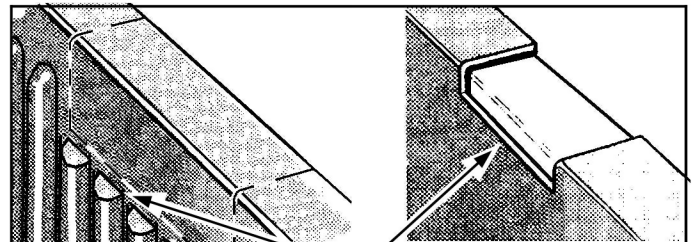

Figure 3A

Modify the Bed Liner as needed to make the Lid Hinge Bracket sit and fit well.

3B Place the Front Hinge Bracket on the front of the bed and line it up so the hinge slot is centered on the "A" & "B" lines that you marked of the rear of the Truck Cab. Drill two $\frac{1}{8}$ " holes in the top of the rear vertical slots and then drive the screws in to hold the Bracket in place.

Drill the top holes and install the screws in the top of the Bracket in the same manner. The top screws should be located at the rear of the slot as shown in the illustration. This will allow some movement of the Hinge Bracket should spacers be required.

CAUTION: MAKE SURE THE HINGE BRACKETS DO NOT MOVE WHILE YOU ARE DRILLING THESE HOLES.

Repeat Step 3 for the other side of the truck bed.

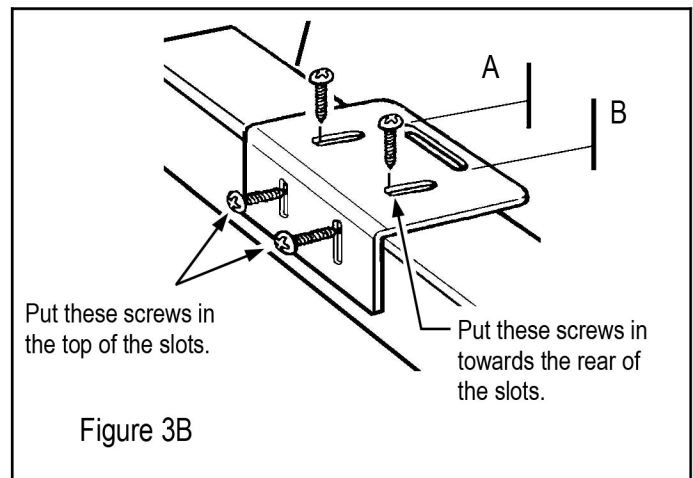

Figure 3B

4 After the Front Hinge Brackets have been install, place the Lid on the truck bed as shown in Figure 4A. It's best to have 3 people available when you engage the Lid Hooks into the Front Hinge Bracket.

The two people holding the front of the lid will guide the hooks into the slots as shown in Figure 4B. The third person will hold the rear of the lid up while standing in the truck bed. After the Hinge Hooks engage, lower it down onto the bed and see how it fits.

5 Things to do to adjust the fit of the Lid.

- **Lid not centered.** If the Lid is not centered on the truck bed, then you will have to be more careful when you repeat Steps 1, 2, & 3. Be careful and accurate with your measurements.
- **Lid is skewed or angled.** If the Lid is centered at the front but too close (because it's skewed or angled) to one side or the other at the rear then add one or more plastic Spacers. Add the Spacers between the Hinge bracket and the bed on the side **opposite of the side** where the Lid is too close to the truck body. Add the plastic spacers between the Front Hinge Bracket and the front bulkhead as shown in Figure 4B.
- **Lid fits too tight along the tailgate.** Add plastic spacers between the Hinge bracket and the bed on to move the Lid towards the rear. Add the same number of spacers on each side. The distance between the surface of the tailgate and the outside surface of the lid should be between 3/8" and 1/2". If the measurement is less than 3/8", then the rubber seal might rub the paint off over a period of time.

6 Mounting the Gas Shock Brackets. Lift the Lid and open the tailgate and then close the Lid. Crawl into the Truck Bed with a flashlight, tape measure and grease pencil. Measure and mark the "X" distance from the Lid Shock Bracket along the bed rail towards the tailgate as shown in Figure 6B.

The "X" distance that you will use depends on the size of the gas shock that came with your Lid. See Figure 6A.

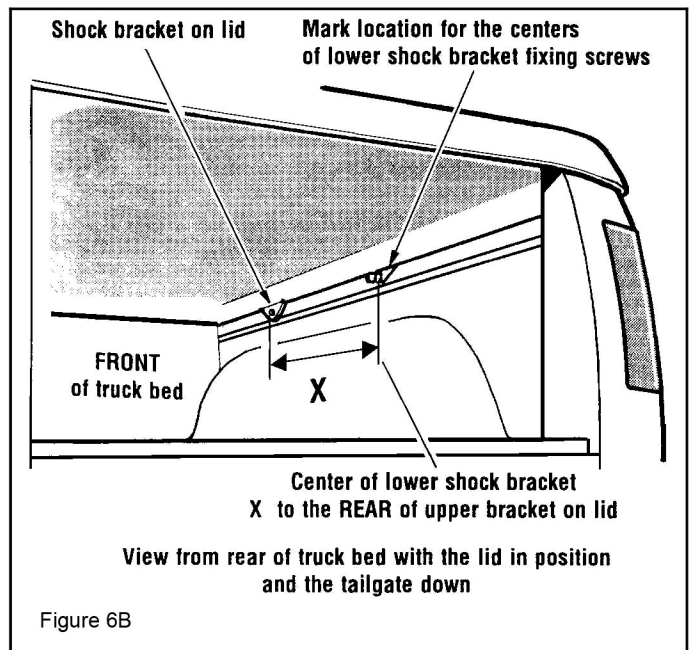
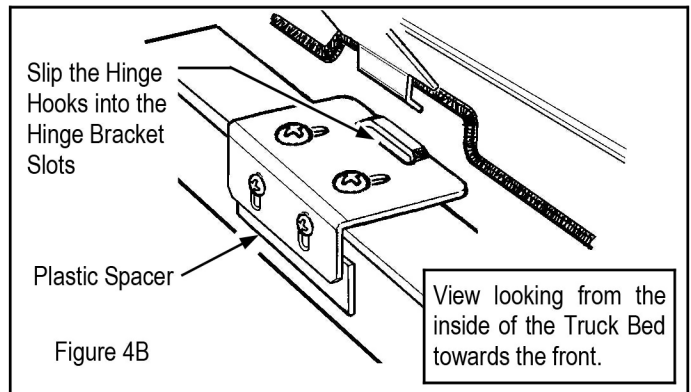
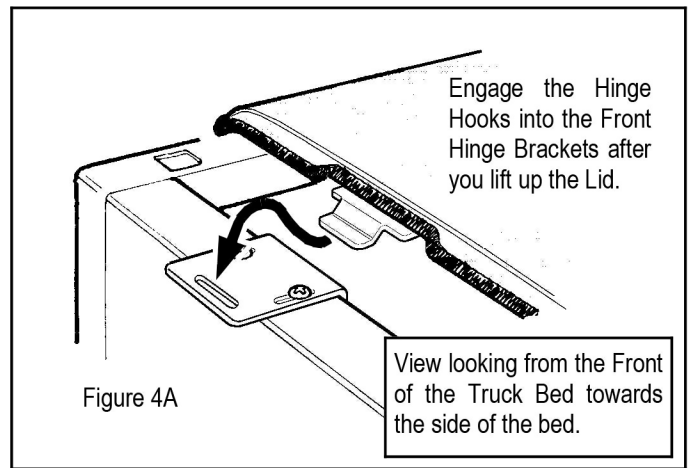
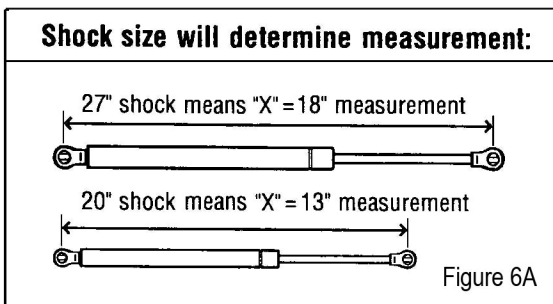

7 Installing the Lock Cams. Remove them from the storage location on the pull-down strap mount. Open the tailgate and close the Lid. Install them on the ends of the lock shafts between the 2 nuts and lock washers as shown below. Finger tighten only.

Note: Plastic bed liners may have to be modified by cutting in order to make the Lock Cams & Striker Plates fit correctly.

8A Mounting the Lock Striker Plates. Turn the locks to the lock position. Use a pencil to mark the center of the Lock Cam on both sides of the truck bed. Unlock the locks and open the lid. Remove the paper cover from the tape to expose the adhesive. Center the Lock Strikers over the pencil marks and press firmly in place.

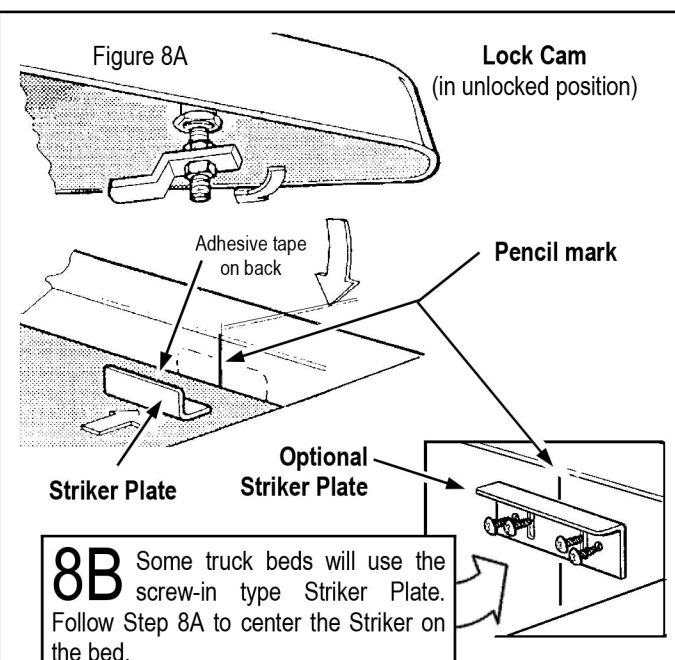

WARNING! THIS TRUCK LID CAN BE HAZARDOUS IF INSTALLED OR OPERATED INCORRECTLY.

Read the instructions prior to installing or operating the lid. SEVERE INJURY can result if you do not follow these instructions and warnings. **Please read this carefully.**

- Always open the truck lid fully before reaching into the truck bed. The lid may accidentally close if not fully opened.
- Never place or carry items on the top of the truck lid.
- Never install any accessories on the truck lid.

The lifting forces generated and that act on the lid when the truck is moving may cause the lid to lift and may cause it to disengage from the truck. To prevent this, keep the following points in mind:

- Always close and lock the lid when driving the truck.
- Always close and lock the lid even when towing the truck.
- Always close and lock the lid when transporting the truck on a flatbed tow truck and **NEVER** transport the truck with the rear of the truck pointing in the direction of travel.

9 Lock Cam adjustment. Close the Lid with the tailgate open. Adjust the two Lock Nuts so that the Lock Cam just touches the striker Plate. Turn the Lock to the unlock position. Turn both Lock Nuts so that they move upwards 1 or 2 turns. Tighten the lower Lock Nut firmly against the Lock Cam. Turn the Lock to the lock position to see how the locking action feels. Readjust the two Lock Nuts until the action feels correct. If too much force is required, turn both nuts so that they move downwards or turn the nuts upwards to reduce the gap between the Lock Cam and the Striker Plate.

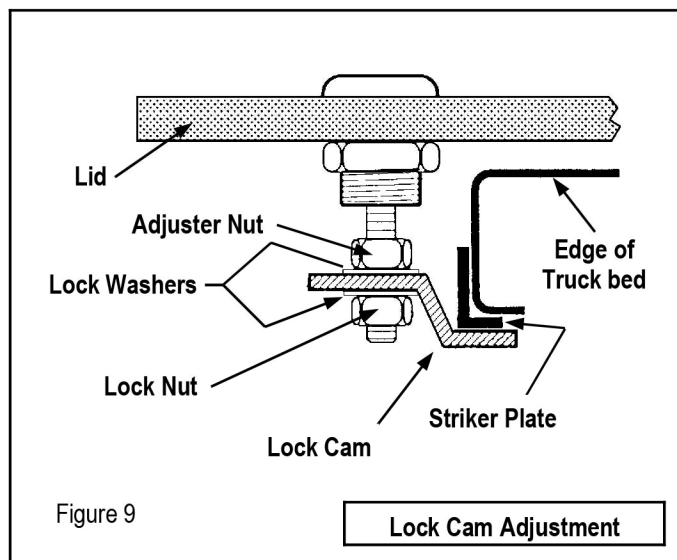

WARNING: The Locks must always be in the UNLOCKED POSITION before closing the Lid. Failure to do this will damage the locks and will damage the truck body and scratch the paint.

10 Check all fastenings. Check that all the fasteners are secure and that the Lid operates correctly. Check that the Locks operate correctly in closed position. Make sure when the Lid opens and closes that it does not scrape against any of the vehicle's body work. Congratulations! You've just finished your installation. You can now enjoy the benefits your Gaylord's Kustom Lid!

Please take the time to clean and wax your lid about once a month. Doing so will keep your investment looking brand new longer.

FATAL MOTORSPORTS / 3040 N Simmons St #102, North Las Vegas, NV 89032 (702) 363-9779